

SEMICONDUCTOR, WAFER, DIAMOND AND UHP APPLICATIONS

Expert in ultra-trace gas analysis for over 30 years

When it comes to UHP gas analysis, the pace at which it advances has been quite a driver for us. To remain at the forefront, we've had to develop innovative solutions rapidly, constantly evolving to meet more and more stringent requirements. As a result, we're proud to say that we offer the most advanced, innovative range of semiconductor, wafer, diamond and UHP solutions in our field—and our portfolio is proof of our commitment to you.

Applications

- IQC: Pre-Purification H₂, O₂, N₂, Ar, He, CO₂, CDA purity analysis
- CQC: Post-Purification H₂, O₂, N₂, Ar, He, CO₂, CDA purity analysis
- Total base analysis in CO₂ and CDA
- Total acid analysis in CO₂ and CDA
- Ultra-trace analyzer calibration
- Specialty gases (SiH₄, etc.) analysis

Product offering

- Gas chromatographs
- Continuous trace oxygen analyzer
- Continuous trace nitrogen analyzer
- Trace calibration system
- Sampling systems
- Process ion chromatographs

ASDevices

We are innovators, engineers and pioneers.

When an analytical component or method limits the performance we desire, we innovate to overcome it and make it available to the broader GC community. That has been in our DNA for the past 30 years.

Our game-changing inventions throughout the years

1992

Plasma detector for trace N₂ analysis

1995

New method to reduce H₂O interference on N₂ measurement

2000

First Ar in O₂ separation column

2001

First fully integrated process GC for trace N₂ and Ar in O₂ for semiconductor industry

2004

New UHP gas sampling system

2005

First purged diaphragm valve

2007

First purged conical rotary valve

2016

New extended lifetime principle for noble gas purification

LipLOK fitting to improve fitting leak integrity and reduce dead volume

2017

Enhanced plasma discharge sensing technology

2018

PLSV GC valve technology

2019

Modular GC oven

PLSV valve for trace sulfur analysis

GCS trace gas calibration system

2020

New method for trace sulfur analysis in H₂

PPDV purged diaphragm valve technology

2023

New PLSV valve compatible with third-party actuators

2024

KA5800 Process Ion Chromatography

2025

Trace O₂ analyzer and ion chromatograph release

What we can do **for You**



We've dedicated our careers to the continuous improvement of the gas chromatography field. Using only the highest-quality components, we've designed cutting-edge technologies for a host of industries, and had our solutions validated by specialists in each field to ensure that they not only meet but exceed their needs.

From our revolutionary permanent gas concentrator to our ultra-sensitive patented enhanced plasma discharge (Epd) technology (that can measure in the ppt range) and our groundbreaking PLSV GC valve (that offers unsurpassed leak integrity and performance), we're equipped with all the key components you need, both for now and in the future. What's more, we've implemented the latest advancement in signal processing into our ASDSense GC software, so we can offer you even more precise, sensitive measuring capabilities.

A complete **ecosystem**

Improving Measurement Accuracy

Our leading-edge analytical solutions are designed to work in harmony with our selection of supporting accessories—such as our sample concentrator or our purifiers—to improve performance, all while simplifying your life.

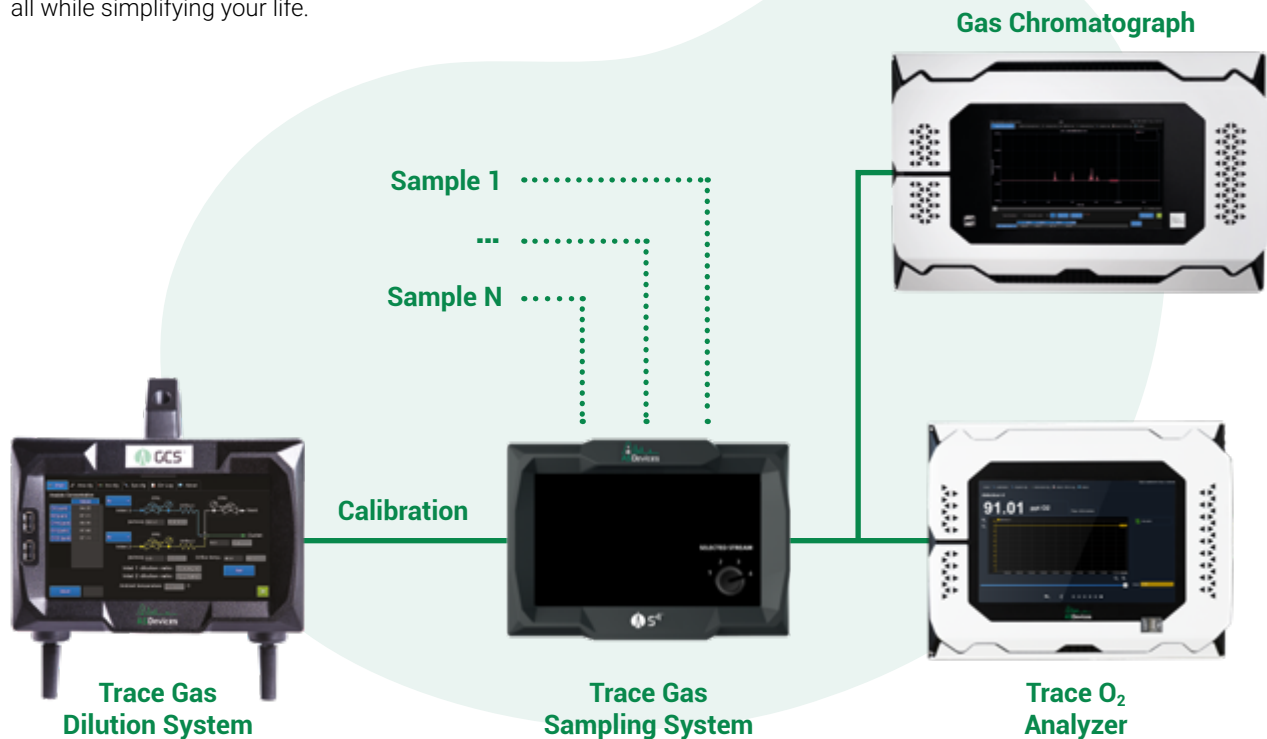

Offering a complete solution for accurate trace analysis



Ultra-Trace Gas Chromatography for the Most Demanding Purity Applications

Delivering ppt-level detection, unmatched sensitivity, and reliable impurity monitoring for semiconductor bulk gases.



Ultra-Trace Oxygen Measurement with Unmatched Stability

Non-depleting coulometric sensing technology delivering accurate ppb and ppt oxygen monitoring for critical gas purity control.



True Ultra-Trace Calibration You Can Trust

High-precision dilution technology enabling accurate ppb-level calibration and validation of analytical systems.



Continuous Ion Monitoring for Critical Process Control

High-sensitivity ionic contamination analysis designed for real-time semiconductor process monitoring.



Ultra-Pure Carrier Gases for Ultimate Analytical Performance

Advanced dual-vessel purification technology delivering <1 ppb impurity levels without hydrogen release.



Leak-free multi-stream sampling for ultra-Trace Analysis

PLSV valve-based stream selection ensures unmatched sample integrity and eliminates cross-contamination in UHP gas systems.

Key applications

With decades of experience in ultra-trace gas analysis, ASDevices delivers the expertise required for the most demanding semiconductor applications.

From post-purification Incoming Quality control (IQC) to Continuous Quality control (CQC) monitoring, we provide advanced solutions for precise gas analysis, reliable sampling and accurate calibration.

Our technologies enable manufacturers to maintain the highest standards of gas purity and process integrity.

Application	Gas matrix	Impurities	Typical analytical ranges	Typical LOD	Products	
ICQ Bulk gases pre-purification quality control	<ul style="list-style-type: none"> Ar CDA CH₄ CO₂ 	<ul style="list-style-type: none"> He H₂ N₂ O₂ 	<ul style="list-style-type: none"> Ar CH₄ CO CO₂ H₂ H₂S N₂ Ne NHMC O₂ 	0–10 ppm	0.01 ppm	<ul style="list-style-type: none"> KA8000Plus KA6000Plus KA5000Plus KA 343 KA 344
CQC Bulk gases post-purification quality control	<ul style="list-style-type: none"> Ar CDA CH₄ CO₂ 	<ul style="list-style-type: none"> He H₂ N₂ O₂ 	<ul style="list-style-type: none"> CH₄ CO CO₂ H₂ H₂S N₂ Ne NHMC O₂ 	0-100 ppb	0.1 ppb	<ul style="list-style-type: none"> KA8000Plus KA6000Plus KA5000Plus KA345 KA346
Purifier testing	<ul style="list-style-type: none"> Ar CDA CH₄ CO₂ 	<ul style="list-style-type: none"> He H₂ N₂ O₂ 	<ul style="list-style-type: none"> Ar CH₄ CO CO₂ H₂ H₂S N₂ Ne NHMC O₂ 	0-100 ppb	0.1 ppb	<ul style="list-style-type: none"> KA8000Plus KA6000Plus KA5000Plus KA 345 KA 346
Leak testing	<ul style="list-style-type: none"> Ar H₂ He 	<ul style="list-style-type: none"> N₂ O₂ 		0-10 ppb	1 ppb	<ul style="list-style-type: none"> KA8000Plus KA6000Plus KA5000Plus KA 345 KA 346
Mobile testing	<ul style="list-style-type: none"> Ar CDA CH₄ CO₂ 	<ul style="list-style-type: none"> He H₂ N₂ O₂ 	<ul style="list-style-type: none"> CH₄ CO CO₂ H₂ N₂ Ne NHMC O₂ 	0–1000 ppb	1 ppb	<ul style="list-style-type: none"> KA8000Plus KA6000Plus KA5000Plus KA343 KA344
Specialty gases	<ul style="list-style-type: none"> C₂F₆ C₄F₆ C₄H₈ CH₃F 	<ul style="list-style-type: none"> NF₃ SiH₄ Others 	<ul style="list-style-type: none"> Ar CH₄ C_mH_m CO CO₂ H₂ O₂ 	0–1000 ppb	1 ppb	<ul style="list-style-type: none"> KA8000Plus
Total acid and base analysis	<ul style="list-style-type: none"> XCDA CO₂ 		<ul style="list-style-type: none"> Total acid Total base 	<ul style="list-style-type: none"> 0–10 ppt 0–50 ppb 0–10 ppm 	10 ppt	<ul style="list-style-type: none"> KA5800Plus
Trace calibration	<ul style="list-style-type: none"> Ar CDA CH₄ CO₂ He 	<ul style="list-style-type: none"> H₂ N₂ O₂ Others 	<ul style="list-style-type: none"> Ar CH₄ CO CO₂ H₂ H₂S N₂ Ne NHMC O₂ Others 	NA	NA	<ul style="list-style-type: none"> iGCS

Ultra-trace gas chromatograph

We offer two analytical solutions to meet your needs in the most cost-effective way. Both use the same electronics and software and offer the same performance. The difference is related to the number of valves, columns and features such as ramping oven capability that is only offered in the KA8000plus.

KA8000plus

Our most advanced rackmount process gas chromatograph



Our most advanced solution, the KA8000 series is based on the iMOv platform. Its modular oven design allows for 6 GC valves, 2 detectors and multiple parallel chromatographic channels to be integrated and, it even offers a heated valve box and a ramping oven.

Features

- Up to 2 gas detectors and up to 4 with SePdd Quattro
- Up to 6 thermal zones, isothermal and ramping oven capability
- Ambient or heated valve capability
- Up to 6 chromatographic valves
- All key GC components are accessible from the front panel, for easy maintenance
- Rackmount configuration
- Auto-sampler option

Applications

- **Impurities measured:** H₂, Ne, Ar, N₂, CH₄, CO, CO₂, NMHC, H₂S, Sulfurs
- **Matrices:** H₂, O₂, Ar, N₂, CO₂, CH₄, SiH₄ and many others.

KA6000plus

Rackmount process gas chromatograph

Based on our GCsense platform, this high-quality solution is ideal for the integration of medium complexity GC configurations, where up to 5 valves and up to 2 detectors are required. What's more, a large touchscreen display makes it easy to operate.



Features

- 4U 19 inches rackmount configuration
- Up to 4 isothermal zones
- Up to 5 chromatographic valves
- Up to 2 gas detectors

Applications

- **Impurities measured:** H₂, Ne, Ar, N₂, CH₄, CO, CO₂, NMHC, H₂S, Sulfurs
- **Matrices:** H₂, O₂, Ar, N₂, CO₂, CH₄, SiH₄ and many others.

Choose your platforms, according to your needs:

	KA8000Plus	KA6000Plus
Number of detectors	2	2
Number of thermal zones	6	4
Number of GC valves	6	5
Number of electronics pressure controllers	5	4
Ramping oven capability	Yes	No
Valves and column accessible from front door	Yes	No
19" rackmount	Yes	Yes

Typical minimum detection limit for key applications

Typical sample gas		Minimum Detection Limit (ppt)						
Matrix	Range (ppb)	H ₂	N ₂	CH ₄	CO	CO ₂	NMHC	Ar
Helium	0–250	70	60	70	75	70	100	75
Argon	0–250	70	60	70	75	70	100	–
Oxygen	0–250	70	60	70	75	70	100	75
Hydrogen	0–250	–	60	70	75	70	100	75
Nitrogen	0–250	70	–	70	75	70	100	75

Note: Other ranges available. Minimum Detection Limit is based on 3 times signal-to-noise.

Sample gas		Minimum Detection Limit (ppt)						
Matrix	Range	H ₂	N ₂	CH ₄	CO	CO ₂	NMHC	Ar
Helium	0–250	100	100	100	200	100	250	100
Argon	0–250	100	100	100	200	100	250	–
Oxygen	0–250	100	100	100	200	100	250	100
Hydrogen	0–250	–	100	100	200	100	250	100
Nitrogen	0–250	100	–	100	200	100	250	100

Note: Other ranges available. See AN-20 for limit of detection definition and method.

Typical repeatability & LOQ for key impurities

Analysis #	Measurement (ppb)						
	N ₂	H ₂	CH ₄	CO	CO ₂	NMHC	Ar
1	3.59	3.79	3.47	4.26	3.99	4.00	3.97
2	3.93	3.96	3.46	4.68	3.7	3.67	3.73
3	3.96	3.91	3.59	4.54	3.61	3.64	3.58
4	3.97	3.94	3.61	4.58	3.87	3.89	3.83
5	3.83	3.85	3.66	4.61	3.73	3.73	3.74
6	3.79	3.89	3.67	4.5	3.86	3.82	3.83
7	3.47	3.77	3.53	4.5	3.54	3.57	3.55
8	3.77	3.89	3.50	4.65	3.71	3.69	3.70
9	3.77	3.87	3.48	4.55	3.73	3.76	3.72
10	3.95	3.92	3.52	4.34	3.98	3.95	3.98
Average (ppb)	3.803	3.879	3.549	4.521	3.772	3.776	3.768
Repeatability (ppb)	0.167	0.061	0.078	0.132	0.149	0.139	0.143
LOQ (ppb)	0.5	0.18	0.23	0.4	0.45	0.42	0.43

KA34X Series

Redefining Trace Oxygen Measurement



Our ultra-trace oxygen analyzer delivers exceptional **stability, accuracy, and uptime at the lowest detection levels**, while minimizing maintenance and operator intervention. **Automated electrolyte replenishment** enables reliable ppb-level measurements over extended periods, keeping continuous processes running without interruption. This performance is driven by a patent-pending, purged cathode, non-depleting coulometric sensor. To ensure complete confidence in every reading, an optional embedded sonic-orifice dilution system provides true trace-level calibration, eliminating ppm-level extrapolation errors and delivering accurate calibration directly at just a few ppb.

Features

Ultra-trace precision

- **True zero stability** with our purged-cathode design (patent pending) that blocks ambient O₂ ingress.
- **Purged gas can be generated internally** from sample gas or from external source.
- **Uncompromising measurement accuracy** with built-in optional sonic-orifice calibration system for true ppb calibration and a purged electronics flow controller.
- **UHP sample integrity guaranteed** with a leak-free stream-selection system using CVProducts (an ASDevices division) patented purged PLSV valve.

Low maintenance

- **No weekly checks, no top-ups:** a built-in deionized water (DI) reservoir with automatic level control enables year-long, worry-free operation.
- **Non-depleting sensor technology** for long life and stable performance.
- **Auto-calibration** maintains accuracy while minimizing operator intervention.

Ease of use

- **Clean, spill-free electrolyte changes** thanks to a dual-valve design that keeps the sensor untouched.

Analytical specifications

	KA341	KA342	KA343	KA344	KA345	KA346
Measurement range	0–10000 ppm	0–1000 ppm	0–100 ppm	0–100 ppm	0–20 ppm	0–20 ppm
Limit of Detection (LOD)	2.5 ppm	250 ppb	50 ppb	3 ppb	200 ppt	45 ppt

Featured Highlights

Purged cathode and electrolyte reservoir

O₂ Shielding for Unmatched Signal Integrity

Our dual-purge approach ensures unmatched signal stability, especially at ppb and ppt levels, and extends the lifetime of both the sensor and electrolyte.

Microscopic air leaks around the cathode housing can cause offsets, drifts, or unexplained signal spikes—problems that plague conventional designs. Our design eliminates this vulnerability with a fully purged cathode shield, creating a controlled barrier that blocks ambient oxygen from reaching the sensing elements.

We take protection even further by purging the electrolyte reservoir itself, preventing oxygen and CO₂ from diffusing into the electrolyte over time—a common issue in designs that leave the reservoir open to atmosphere.

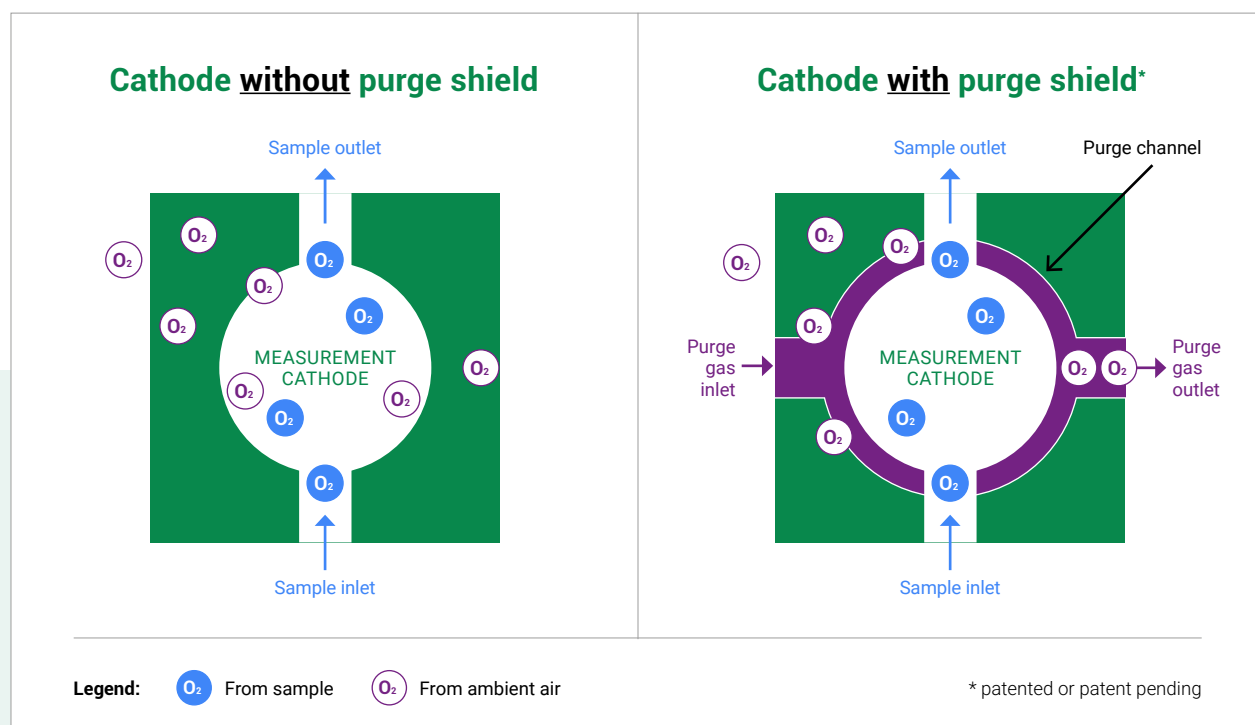

Smart Electrolyte Control

One Fill. One Year. Zero Worry.

The KA34X series is designed to eliminate routine electrolyte maintenance and the risks that come with it. Unlike conventional analyzers that require frequent manual checks and refills, the KA34X series automatically maintains optimal electrolyte levels using an integrated pump and onboard deionized water reservoir. This enables up to one year of unattended operation, reducing maintenance while ensuring stable, reliable measurements.

When electrolyte replacement is required, service is fast and safe. A closed, valve-based drain and fill system allows clean replacement without removing or exposing the sensor—eliminating spills, contamination, and downtime. The result is a smarter, safer, and lower-maintenance analyzer that protects both your process and your data.

KA5800 Series Process Ion Chromatography



The KA5800 is the first process oriented Ion Chromatographic solution. This innovative solution offers a unique sample introduction system based on an optimized gas to liquid injection principle. This guarantee the best sample recovery rate and hence the most accurate measurement. In addition, to this, our solution offers a fully automated eluent recycling system, offering a low-maintenance solution. The combination of our application know hows, relentless innovation is now making total acid and total base analysis on process a reality.

Features

- **Process-Optimized Ion Chromatography:** Designed specifically for continuous, on-line analysis in demanding process environments.
- **Advanced Gas-to-Liquid Injection System:** Maximizes sample recovery for superior accuracy and repeatability.
- **Wide measurement range:** From 10 ppt to ppm, covering ultra-trace to high concentrations.
- **Automated Eluent Recycling:** Reduces reagent consumption and maintenance, lowering overall operating costs.
- **Real-Time Total Acid & Base Analysis:** Enables continuous monitoring for improved process control and decision-making.

Applications

- Total acid in XCDA
- Total base in XCDA
- Total acid in CO₂
- Total base in CO₂

Impurities measured

Impurities	Range	LOD	RSD	Linearity
Total Acid: CH ₃ COOH, HBr, HCL, HF, NO, NO ₂ , SO ₂ , SO ₃ , etc.	0~10 ppm/ 0~1 ppb	2 ppb/ 10 ppt	<1%	10 ³
Total Base: NH ₃ , NH ₄ , etc.				

Pure

Quantum Leap in Gas Purification

A premium quality gas purifier, the ASD Pure is designed to be robust and provide outstanding performance thanks to its dual vessel technology. It's available in three different flow capacities (300, 1000 and 5000 ml/min) to suit your needs.



Features

- Gases purified: Ar, He, Ne, Xe, Kr (N₂ is also an option)
- Impurities removed: H₂O, H₂, O₂, N₂, CH₄, CO, CO₂, hydrocarbons
- Achievable impurity level: <1 ppb (<5 ppb single vessel version)
- Nominal flow: 300 ml/min, 1000 ml/min and 5000 ml/min
- Lifetime at nominal flow: 2 years
- Proprietary dual vessel technology: No H₂ release

Applications

- Carrier gas purifier
- Zero gas generator for calibration of online analyzers
- Reference gas generator for TCD analyzers
- Mass spectrometer
- Perfect for all kinds of detectors: plasma, HID, DID, FID, PID, TCD, ECD, etc.

Dual heated getter technology

It's well known in the field that traditional heated getter purifiers release trace amounts of H₂ due to both hydrocarbon cracking and the metal being processed at high temperatures. Our proprietary dual-stage purification design unlocks better purification and superior performance. With a second vessel operating at a lower temperature, the H₂ released by the first vessel is reduced to below 1 ppb.

- <1 ppb Purity
- No H₂ release

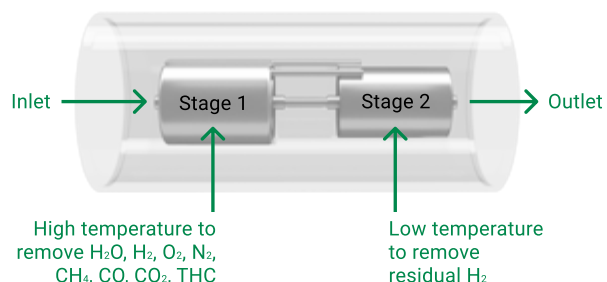

Intelligent Plasma Assisted Purification System (iPAPS™)

Extending Noble Gas Purifier Lifetime Through Controlled Plasma Chemistry

Conventional noble gas purifiers rely on heated getters to remove impurities such as oxygen, water, hydrocarbons, and nitrogen. As these contaminants react with the getter surface, the material gradually loses its reactive capacity.

iPAPS™ adds a controlled plasma stage that activates trace impurities before they reach the getter. Energetic electrons convert contaminants into species that react more efficiently with the purification material, improving impurity capture and optimizing getter utilization.

The result

- longer purifier lifetime
- higher purification efficiency
- more stable ultra-trace gas purity



Preventing hazards with built-in gas verification

The plasma emission array acts as a sensor. By analyzing its optical emission spectrum, the system identifies the gas entering the purifier and confirms compatibility with gases such as helium, argon, or nitrogen.

If an incompatible gas (such as air or oxygen-rich mixtures) is detected, protective actions are immediately triggered to avoid exothermic reactions, preventing hazardous reactions that can cause fire hazard.

Smarter purification

iPAPS™ uniquely combines:

- plasma-assisted impurity conversion
- extended getter lifetime
- real-time gas verification
- protection against hazardous feed gases

A safer, more efficient generation of noble gas purification for ultra-trace gas analysis.

Intelligent gas calibration/dilution system (iGCS)

The data provided by your analytical system is only as accurate as your calibration.

Gas calibration and analytical system performance validation depends on knowing how to accurately dilute gas standards. Our high-end dilution system, based on a laser-calibrated orifice, is the result of over 30 years of experience in the field, so you can count on unparalleled precision.



Features

- Sonic orifice technology with high dilution ratios from 1:2 to 1:3500 (custom up to 1:10000)
- High precision (<0.5%rel.)
- High sample integrity with purged electronics pressure regulator
- Advanced mathematical model to enhance precision and stability
- Heated flow path up to 200 °C
- User configurable orifice
- Optional inert flow path for sulfur and reactive gas analysis
- NIST traceable certificate available

Applications

- Ultra-trace analyzers calibration/validation
- Ultra-trace N₂ and O₂ calibration/validation
- Portable calibration system for on-site calibration
- Gas analyzer manufacturing/quality control
- Gas standard preparation
- Gas analyzer performance validation
- Research and development

Enhanced stability

Pressure and temperature must be stable. That's why we use a highly stable, temperature-compensated pressure sensor in our electronics pressure controller (EPC). What's more, the orifices are installed inside a heated, adjustable enclosure, and the temperature can be adjusted up to 200 °C to better accommodate your gas sample.

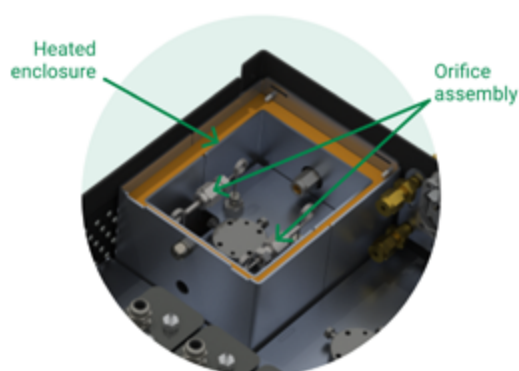

Typical configuration



Benefits of calibrating with ASDevices iGCS

Most ultra-trace instruments designed to measure low ppb levels are calibrated in ppm level leaving doubts about true performance to precisely measure ultra-trace contained in gas. The iGCS was designed for that very reason. Instead of calibrating our instruments with widely available 5 to 10 ppm standard calibration gas, we use our iGCS to precisely calibrate our instruments at just a few 10s of ppb. The result, a more precise and reliable measurement.

Analyte linearity examples

- Nitrogen
- Hydrogen
- Carbon monoxide
- Carbon dioxide
- Methane
- Argon

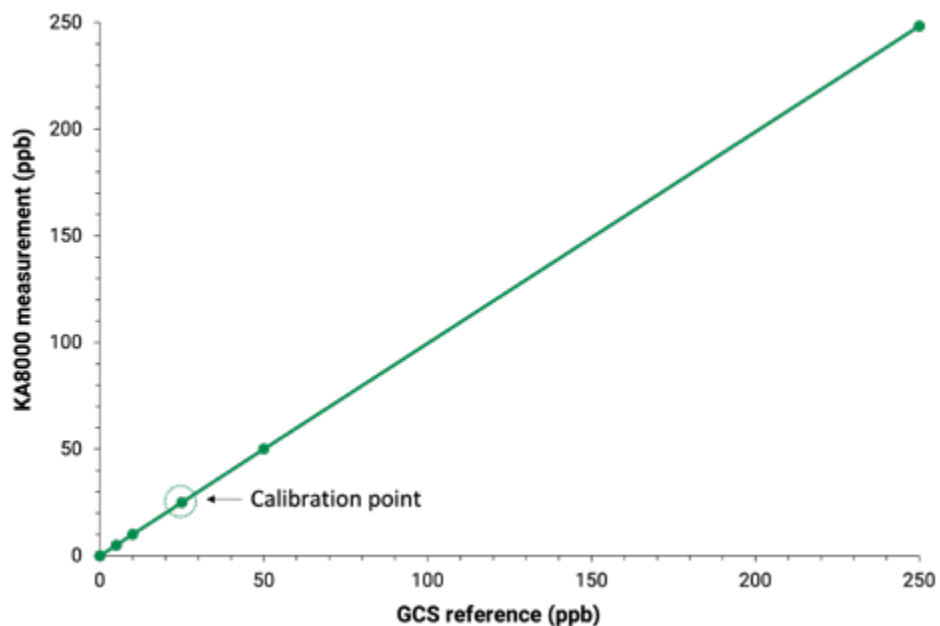

Sample Stream Selection System (S4)

Unsurpassed sample Integrity

We know that sampling system quality greatly impacts analytical system performance. That's why for over three decades, we've been designing only the best sampling solutions, like our innovative sample stream selection system (S4) with our proprietary Purged Lip Sealing Valve (PLSV) that delivers unsurpassed sample integrity.



Features

- Based on Purged Lip Sealing Valve (PLSV) technology
- PLSV technology eliminates cross-port leaks
- 2, 4, 6 and 8 sample inlet versions available
- Manual, automatic or remote control
- No dead or unswept volume
- Stand-alone or integrated with GC platform

Applications

- Industrial gas sampling
- UHP gas sampling
- Electronics gas sampling
- Reference or calibration gas sampling
- Fence line monitoring

Automate multi-stream analysis with our Sample stream selection system (S4) and ASDSense software

- Define number of analysis per stream
- Automatic analytical method switch
- Automatic stream switch
- User configuration purge time

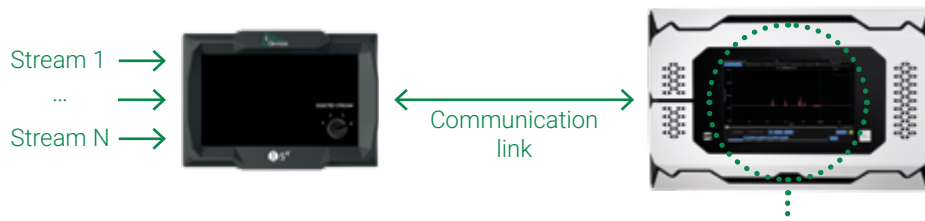

Method configuration		Method sequence			
Name		Method	Number Cycle(s)	Relay	Purge Time [min]
1	N2	1	O2 - 1	-	1
2	O2	2	Ar - 3	-	10.0
3	Ar	3	O2 - 2	-	5.0
4		4	N2 - 1	-	3

Our technologies

Advancing gas chromatography and gas analysis

At ASDevelop, innovation is built right into our DNA. So when we realized that existing technology just wasn't good enough, we began challenging ourselves to develop better, smarter, more cost-effective gas analysis solutions. From products that use less gas to ones that require no spare parts, maintenance or consumables, everything we do is designed to improve efficiency and make things simpler for you—and healthier for our planet.

Semiconductor, wafer, diamond and UHP solutions

Purged Lip Sealing Valve (PLSV)
Page 18

Purged Pulse Diaphragm Valve (PPDV)
Page 19

Enhanced Plasma Discharge (Epd)
Page 20

LipLOK compression fittings
Page 21

Purged electronics pressure controller
Page 22

ArDSieve GC column
Page 23

eLOD algorithm
Page 24

Asynchrone faster analysis
Page 26

Stabilipeak Technology
Page 27



Patented

Purged Lip Sealing Valve (PLSV)

3-year warranty
Certain conditions apply.



The most reliable and durable analytical valves for UHP analysis sample and carrier gas integrity

- **No leaks:** Unique purge technology eliminates inboard/outboard and cross-port leaks
- **Long lifetime:** Over 2 million actuations in UHP applications due to unique reduced surface area insert technology
- **Constant pressure drop:** No change in pressure/flow drop across temperature range and life span
- **No dead volume:** Internal flow path contains no unswept volume.

Leaks Are Virtually Impossible by Design

With its purging channels located between two adjacent valve channels and valve head purging pockets machined into the valve head, our PLSV's unique, patent-pending design does away with leaks. The pockets connect the purging inlet and outlet through the channels, allowing purge gas to flow freely. Since the volume around the insert and in between ports is continuously removed, there are no more inboard/outboard and cross-port leaks.

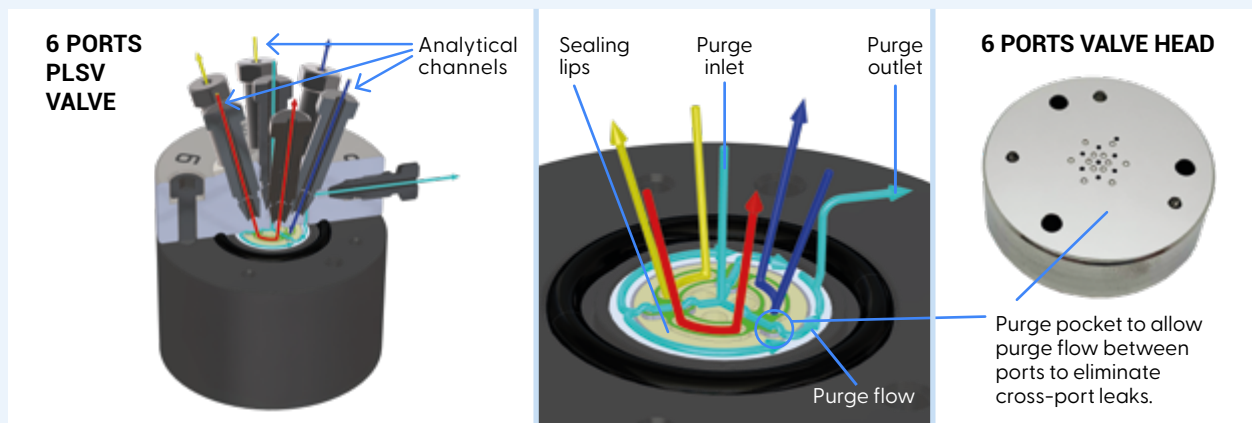

Improves Lifetime With Reduced Surface Sealing Area

Using finite element modeling (FEM) and real-life testing, we optimized the sealing lip size and shape. The result is a sealing surface area that's 14% the size of a standard conical rotary valve, decreasing wear and tear and friction on the valve. What's more, the insert material is specially treated by a proprietary process that improves the surface finish, hardness and creeping.

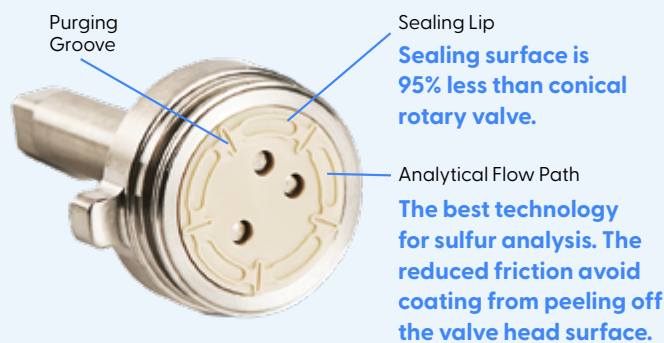

Patented

Purged Pulse Diaphragm Valve (PPDV)



Our Purged Pulse Diaphragm Valve (PPDV) uses the static purge principle to purge the valve's inner volume through the actuation gas. It works for applications that require the features of a diaphragm valve or when better performance is needed from existing applications without design changes.

Static Purge Principle

The system is based on a static purge system that substantially reduces purge gas flow consumption by successive dilution instead of a dynamic (continuous flow) purge concept. This typically results in only 5% of the purge flow consumption compared to a standard purge valve.

Flexible Plunger Seat

Flexible and compressible plunger seat providing movement of freedom to plunger. The result, uniform sealing force on the diaphragm and extended lifetime.

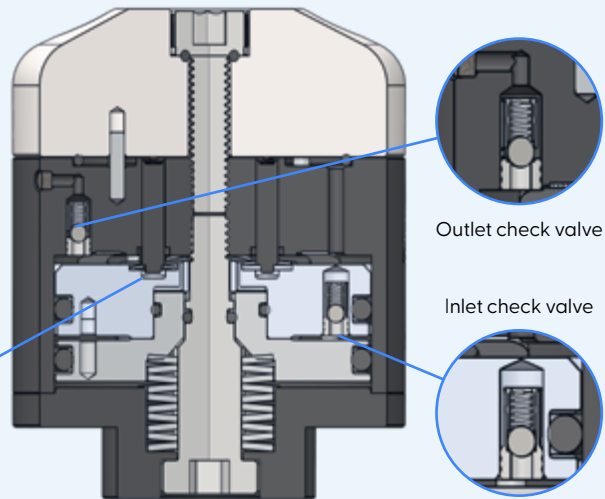
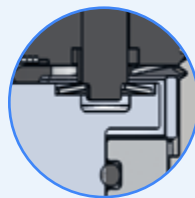

New plunger design

- Purge grooves added to its perimeter to increase air flow and exchange between actuation and under-the-diaphragm volumes.
- Whole plunger base now supported so that the sealing pressure is evenly applied against the diaphragm, minimizing the leak risk and localized diaphragm deformation.
- Plunger's rigid midsection replaced with a compressible one that's separated into three sections for overall flexibility.

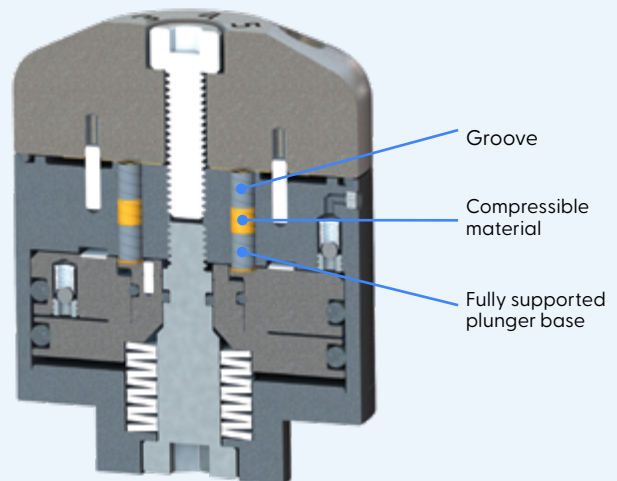



PATENTED

Enhanced Plasma Discharge (Epd)

A Quantum Leap for Gas Chromatography Sensing

The Epd (enhanced plasma discharge) is our proprietary gas detector technology based on a stabilized dielectric barrier discharge (DBD) plasma. The breakthrough resides in the focusing and stabilizing compound electrodes (patent pending) which generate a more stable plasma discharge across a broad range of operating conditions. It uses the highly energetic plasma behaviors to perform measurements. Its versatility and sensitivity make it a technology of choice to measure molecules with high ionization potential, such as the permanent gases, as well as molecules with lower ionization potentials, such as VOCs, hydrocarbons and sulfurs, from ppt to % range.

Stabilized Dielectric Barrier Discharge (DBD)

At the core of our Epd technology, a highly energetic plasma source is used to ionize molecules. Its unsurpassed performance is a result of the Epd stabilized dielectric barrier discharge. The DBD isolates the discharge electrodes from the ionized plasma, eliminating sputtering, cell inner wall coating and analyte interference.

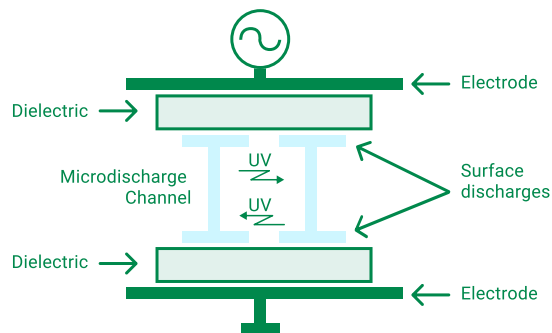

Compound Electrode

This major breakthrough comes from our innovative compound electrode (patent pending). By nature, DBD generates streamer discharges. This results in a noisy signal impacting the signal-to-noise ratio. The main advantage of our technology is that unlike other DBDs or plasma emission detectors (PEDs), our stabilization and electron injection electrodes (patent pending) are embedded in the compound electrode. This enables the electrode to improve stability by sweeping away the accumulation of charges on the inner surface wall.

Our unique compound electrode technology also provides other benefits such as:

- High temperature operation
- High-pressure operation
- Adjustable discharge gap
- Higher ionization potential and efficiency

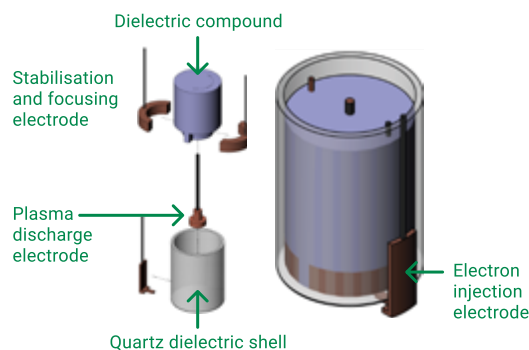

LipLOK compression fittings

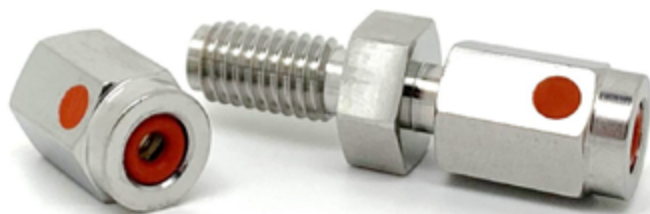

Bringing analytical performance to the industrial/ instrumentation compression fitting

Our LipLOK fitting brings together industrial design analytical performance and robustness with improved leak detection.

It uses two sealing points—the first, a sealing lip, is compression-fit to the tube end, allowing for minimal loss of analytical performance. LipLOK is similar to the VCR fitting but with less dead volume in its flow path. The analytical-grade seal performance is achieved between the tube end and the lip feature using a very low, almost finger-tight torque. The double ferrule design provides the second level of sealing, which resists the effects of vibration and protects against ejection of the tube from the fitting. This is achieved without transferring excessive force to the lip.

No unswept volume and optimized for leak integrity

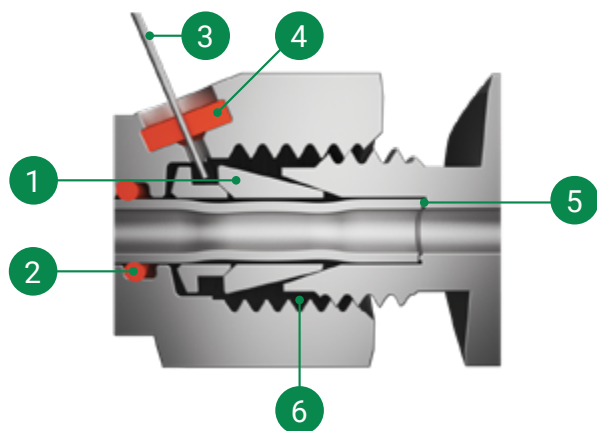

- 1 **Standard front ferrules**
Second level of sealing and tubing swaging action that prevents tube expulsion under high pressure/vibration environment
- 2 **Tubing surface seal and nut sealing ring**
Provide concentration chamber sealing
- 3 **Syringe needle for leak detection**
- 4 **Septum**
Leak detection sniffing with syringe
- 5 **Coated sealing ring**
First level of sealing
- 6 **Leak concentration chamber**
Sniffing: Detect the smallest leaks by accumulating and concentrating them
Tracer: Pressurize the chamber with a tracer gas for leak integrity test

Leak detection system's syringe or sniffing probe

A surface seal has been added to the fitting nut and there is now a seal or septum in the sniffing hole, so any leak that develops inside the fitting will be forced to accumulate in the leak chamber space. The pressure builds up in the chamber until it reaches a certain value, at which point it goes through or around the septum. Inserting the needle of a sniffer or leak detection apparatus allows sensitive leak detection since the leak is concentrated in this chamber.

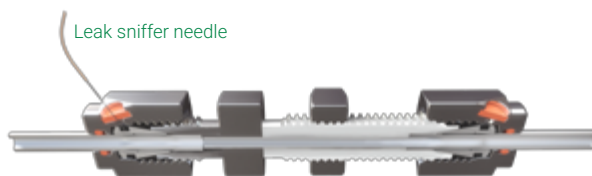

Purged electronics pressure controller

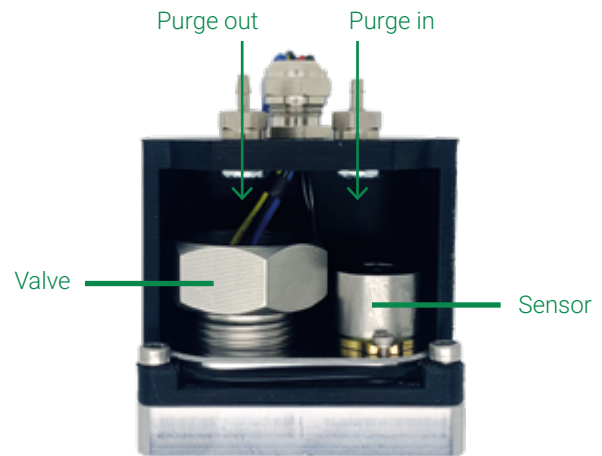

Lower your operating costs by reducing carrier gas consumption by as much as 50%

- No leak with unique purged concept
- Temperature compensated pressure sensor for enhanced stability
- Allow carrier gas to be controlled in inline control mode and reduce carrier gas consumption by as much as 50%.

Leak Integrity

As experts in ultra-trace N_2 analysis, we understand how serious a leak can be. That's why all the components in our proprietary-design electronics pressure controller (EPC) are encapsulated in an enclosure that can be purged using an inert gas such as argon or helium, voiding the effects of any ambient leak. It's an innovative design—one that ensures that sample integrity is preserved.

Inert Flow Path

We offer two sample flow configurations: Inline and bypass. For reactive mixtures, the intelligent gas calibration system (IGCS) can be configured with a by-pass control mode, so that the sample is never in contact with control elements such as the valve and pressure sensor.

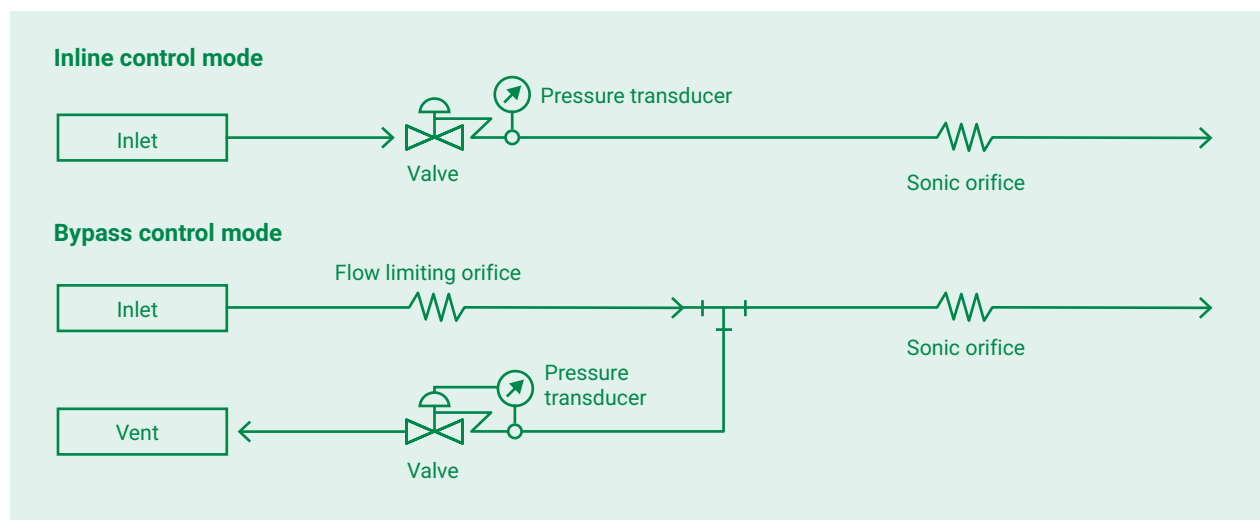

ArDSieve GC column

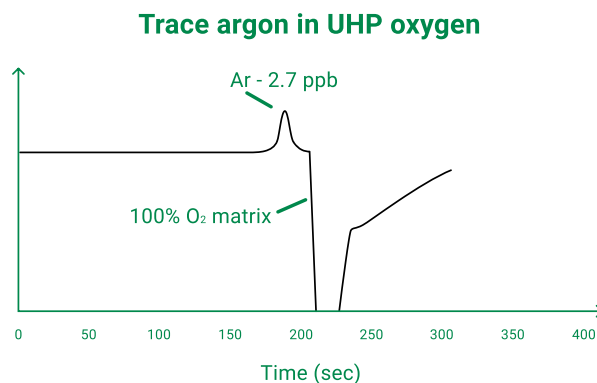

Ar/O₂ separation column

Benefit from a new breakthrough in material science with the ArDSieve chromatographic column, an innovation that separates argon and oxygen molecules at room temperature.

- Ar and O₂ separation at 50 °C column temperature
- Increased durability with proprietary HydraGuard moisture protection layer
- Lower limit of detection compared to GC systems that use O₂ traps
- No need for consumable oxygen trap
- Improved peak symmetry and reduced eddy diffusion with narrow mesh size range (60/65)
- Improved separation compared to other columns due to proprietary plasma oxidation treatment

Proprietary ArDSieve material

The material used in the ArDSieve column is the result of an intensive R&D program and decades of experience. A combination of clinoptilolite, an ion exchanged chabazite, and proprietary treatments, this breakthrough column separates argon and oxygen at room temperature.

Oxidation Treatment

Recent advances in material science have enabled us to better oxidize solid-phase material. A proprietary mixture containing oxygen is introduced into a plasma chamber, considerably improving efficiency and producing higher quality argon and oxygen.

Dehydration and HydraGuard Layer

To achieve proper argon and oxygen separation, it's important to thoroughly dry the column material. We put our decades of experience into developing an enhanced dehydration process that further improves the column's performance. We've also introduced a moisture protection layer called HydraGuard which sits on both sides of the column and eliminates column contamination when manipulating the column or when a contaminated sample is injected.

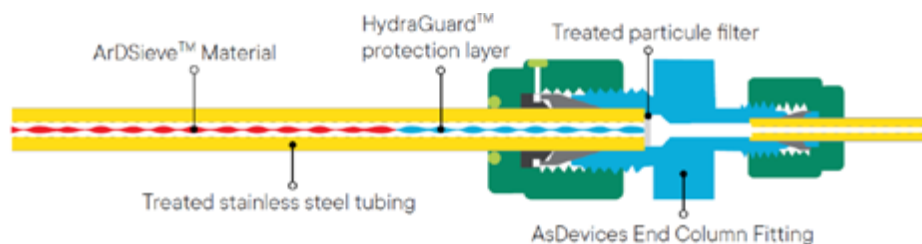

PATENT PENDING

eLOD algorithm

Improving Measurement Accuracy

Over time, the enhanced limit of detection (eLOD) algorithm analyzes and learns the detector's baseline noise and peak shape based on a number of consecutive chromatograms. The learning process allows for a better understanding of the signal's power distribution and differentiates between noises.

- Limit of detection (LOD) is improved by up to 10 times
- Random noise is removed
- Retention time variation is reduced
- Peak shape is improved

eLOD processing method

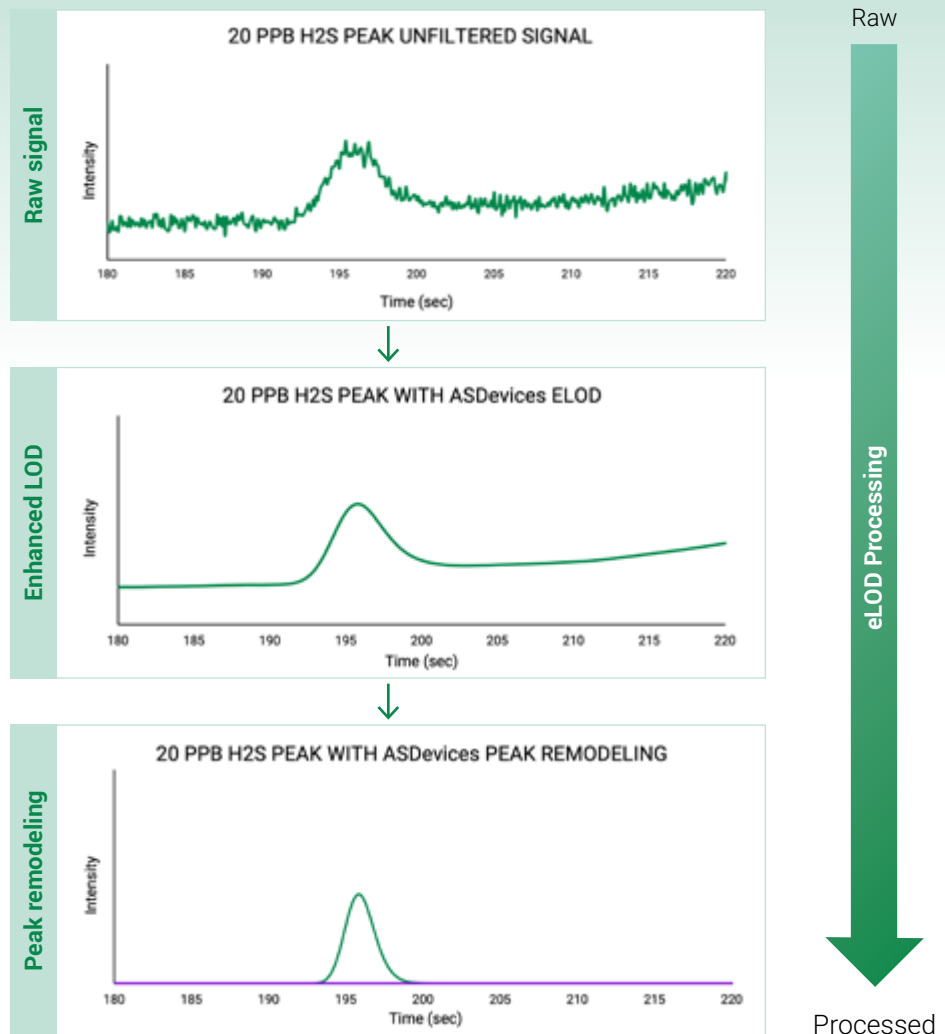

4 ppb permanents in nitrogen

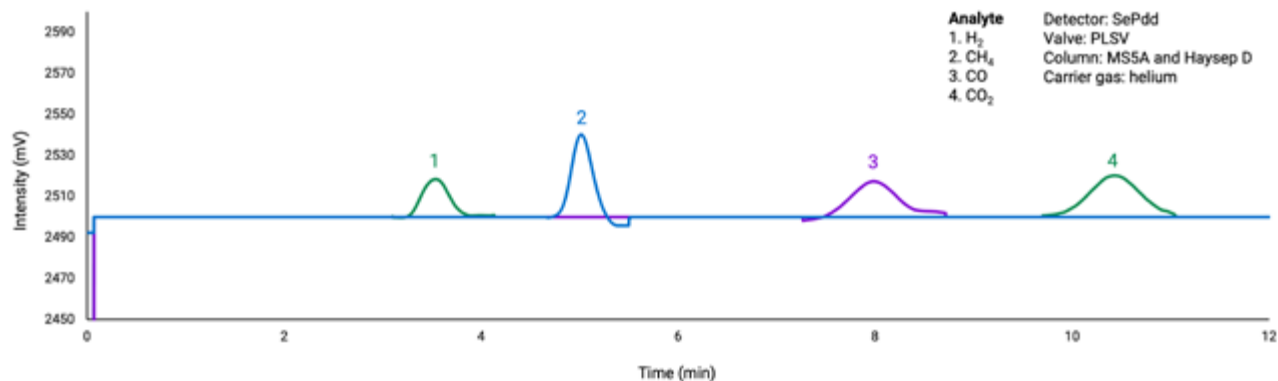

25 ppb Argon in Oxygen

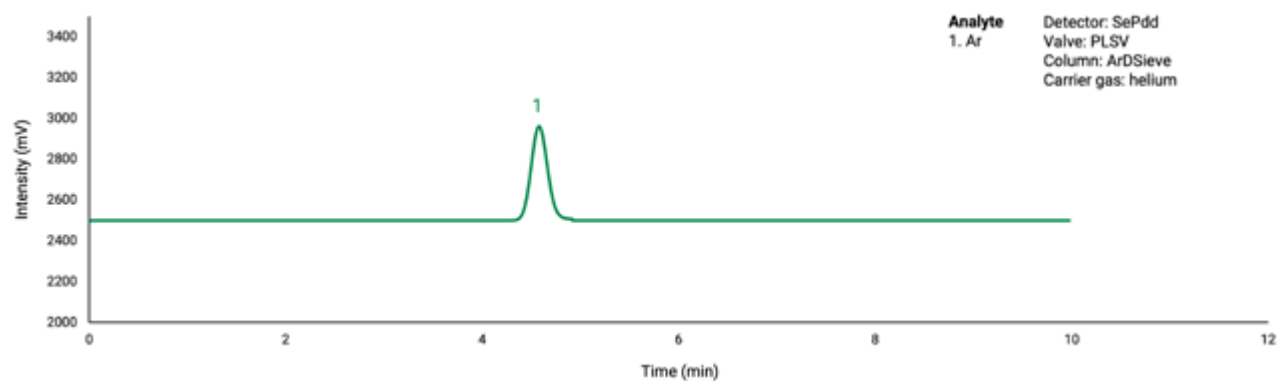

700 ppt H2,N2,CH4,CO and CO2 analysis in helium

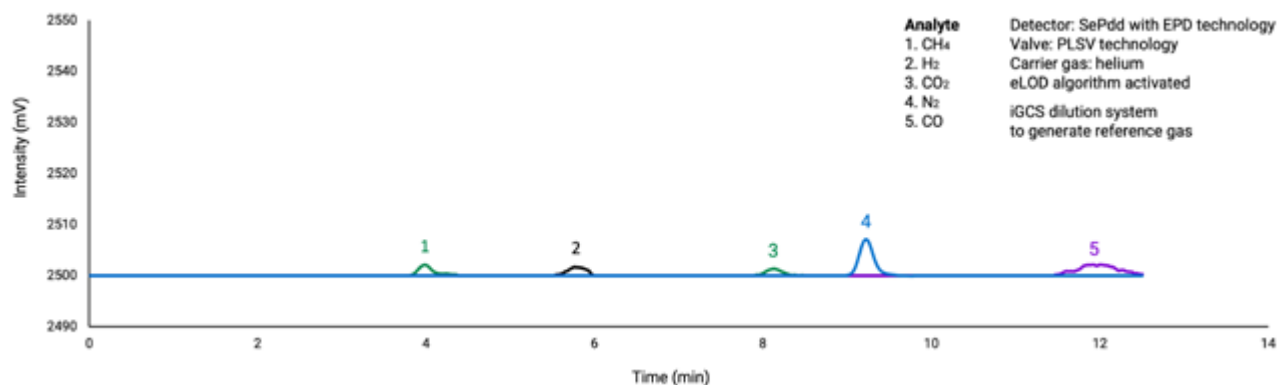

250 ppb permanents in silane

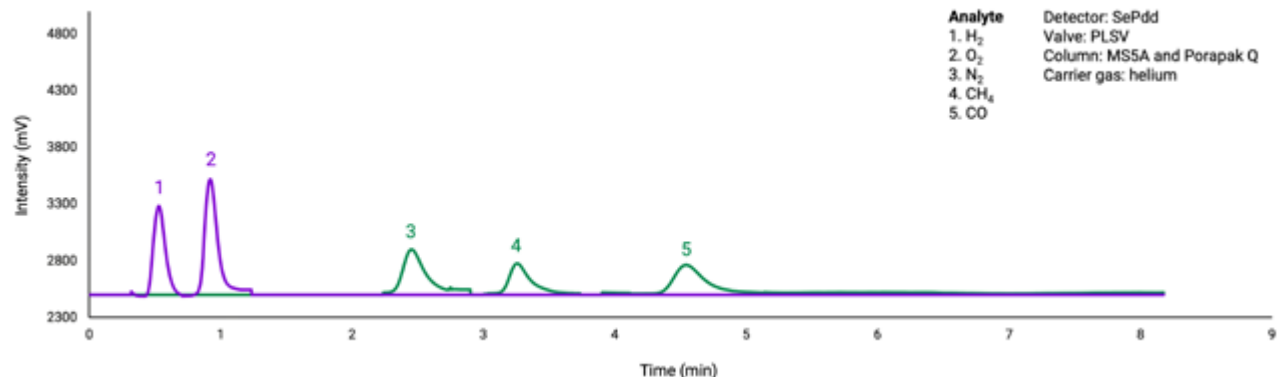

Asynchronous Faster analysis



With ASDSense Asynchronous Technology, Get Faster and More Precise Results

ASDSense is the first process and only GC software to use such an advanced feature. It is very common to ask a process gas chromatograph to run multiple analysis methods in parallel. However, traditional GC softwares are synchronous and not allowing independent method analysis. If one channel requires a 5-minute analysis and another requires a 10-minute analysis, the shorter cycle is slowed down by the longer one. This is a major limitation! As we always want to offer best-in-class solutions, our new ASDSense process GC software supports asynchronous chromatography allowing you to run several analysis in parallel. It will save you time and boost productivity—guaranteed!

Benefits

- Faster data throughput
- Allow faster analysis of key impurities such as N₂ for leak detection
- Improved sensitivity with the combination of faster analysis and eLOD algorithm

Asynchronous (Parallel) Chromatographic Analysis

In chromatography, it's common to have parallel channels. But because traditional GC softwares are synchronous, it's not possible to analyze each one independently. If one channel requires a 5-minute analysis and another requires a 10-minute analysis, the shorter cycle is slowed down by the longer one, and this is a major limitation. As we always want to offer best-in-class solutions, our GC software natively support asynchronous chromatography.

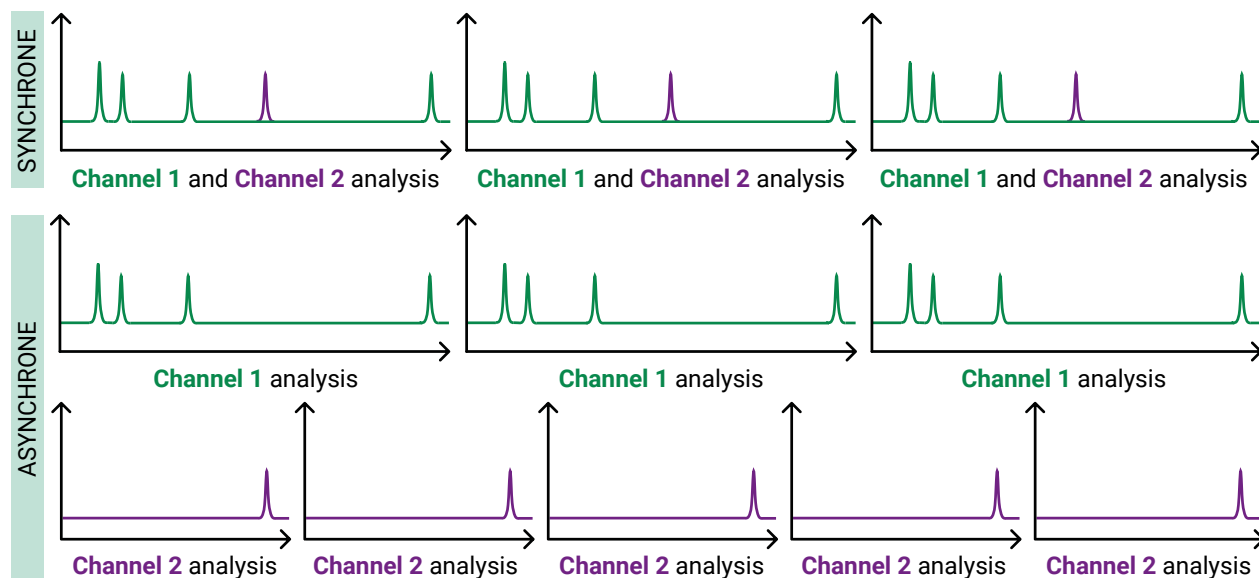

StabiliPeak technology

Make your GC failsafe

A Quantum Leap in Measurement Precision, Stability, and Robustness

ASDevices is introducing StabiliPeak. This patent pending algorithm has been developed and tested during a 2-year R&D program to offer ultra-precise, ultra-stable measurements in the medical market, to precisely detect pathologies such as cancer using VOCs in exhaled breath. It has been validated with Spira Innovations, a company specializing in exhaled breath analysis. The benefit of this algorithm goes well outside the medical market. It is a technology breakthrough for the analytical process industry as well as the semiconductor market.

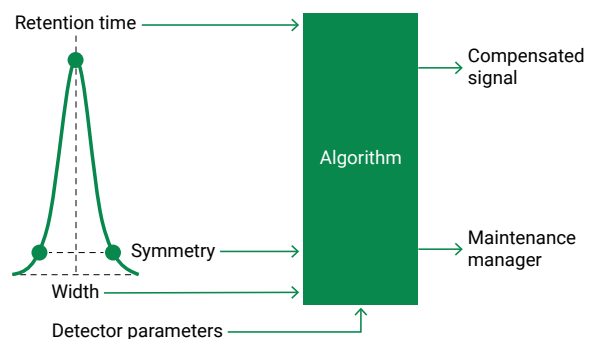

Benefits

- No measurement drift caused by:
 - Ambient temperature variations
 - Ambient pressure variation
 - Analytical components aging
- Avoid false positive or negative measurements
- Improve robustness: Provide a continuous health check of the instrument

Measurement stability improvement

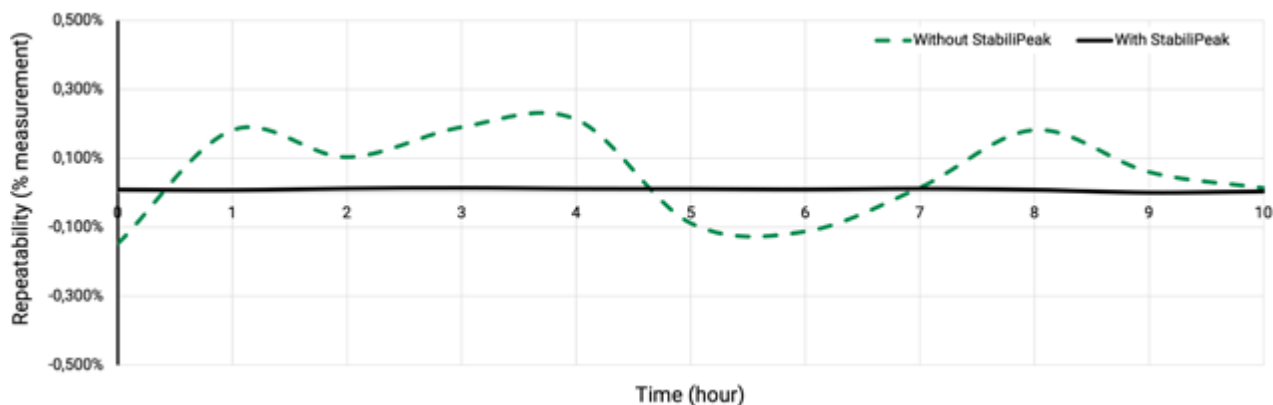

Note: This technology is optional with any of our chromatographs.

Application notes that might interest you

AN-05 – Purged Lip Sealing Valve

AN-08 – A quantum leap for chromatographic valve

AN-13 – Pressure Drop and Dead Volume: PLSV against diaphragm valve

AN-17 – PLSV valve purge technology explained with the leak management principle

AN-20 – Not all limits of detection are the same

Visit www.asdevices.com/documentation

Contact us today!

Interested in our products? Our global team of experts and local partners around the world are at your disposal to answer your questions and evaluate your needs.

sales@asdevices.com

www.asdevices.com

